



EGC37



EGC50



EGC65

Cabinet Construction

- Heavy duty stainless steel countertop and rails with textured laminate, black vinyl exterior.
- Open spaced interior with no walls between compartments.
- Galvanized steel interior.
- 1 3/4" thick high density polyurethane insulation.
- Built-in caster thread receptacles for all models.

Refrigeration System

- Bottom mounted, self-contained and retractable condensing unit uses environmentally friendly, EPA compliant R290 refrigerant with zero (0) Ozone Depletion Potential (ODP) and three (3) Global Warming Potential (GWP). Blizzard R290 is easily replaceable and requires no on-site brazing.
- Electronically commutated (ECM) fan motors achieve rapid cooling with less energy consumption.
- Full-length air duct ensures optimal cold air circulation.
- Time-initiated and temperature-terminated defrost cycle with defrost heater.
- Large capacity, corrosion-resistant condenser and evaporator coils.
- Self-maintaining, energy-efficient condensate drain pan requires no external drains or electric heaters.
- High performance, auto-reverse condenser fan motor supports compressor ventilation and condenser coil cleaning.
- Pre-wired and ready to plug, 115V/60Hz/1Ph, NEMA 5-15P.

Lighting

- Shielded LED bar lighting with on/off switch provides bright, high color illumination at lower heat output.

Lids

- Heavy duty stainless steel exterior and galvanized steel interior.
- 3/4" thick high density polyurethane insulation.
- Removable ratchet locks keep your items safe from theft.

Shelving

- Two levels of epoxy coated, steel wire shelves slide horizontally for easy storage of glasses and plates (see table for quantity).

Temperature Control

- Multi-function digital controller with easy to read LED display.
- Factory preset temperature, -4°F. Temp-set range from -10°F to 54°F.
- Audible overheat protection alarm for compressor and condenser coil.

Options

- 3" or 5" swivel casters with locks.
- 3.5" – 6" height-adjustable and interchangeable legs.

↔ = Interior Dimensions ← → = Exterior Dimensions

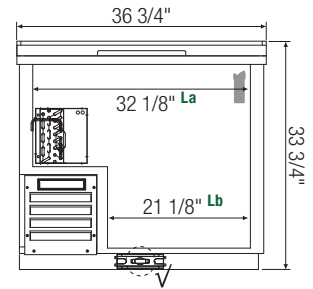
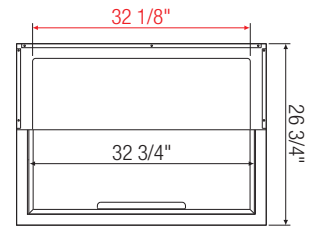
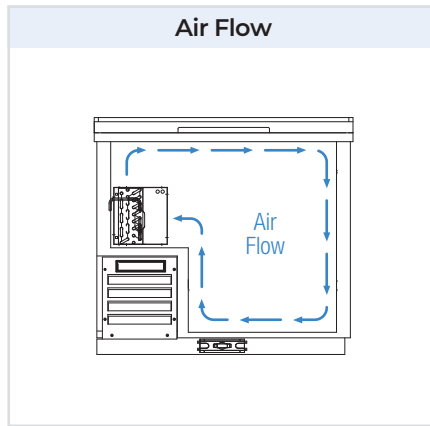
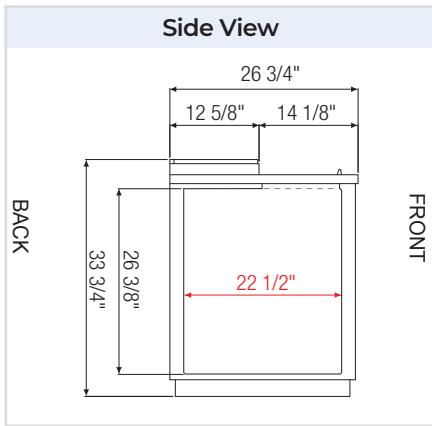

EGC37

√ : Drain

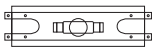

T-Shaped PVC Drain Fittings w/ Movable Plug.

Separate hose attachment w/ 3/4" inner diameter required.



Lids come standard with ratchet locks.



Equipped with 9 ft long NEMA 5-15P plug.

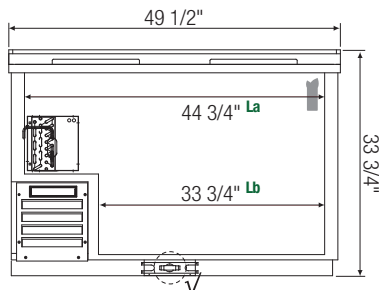
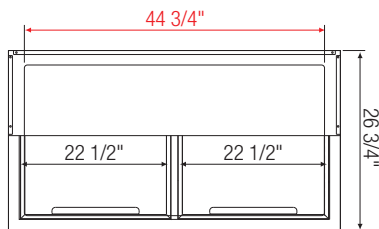

EGC50

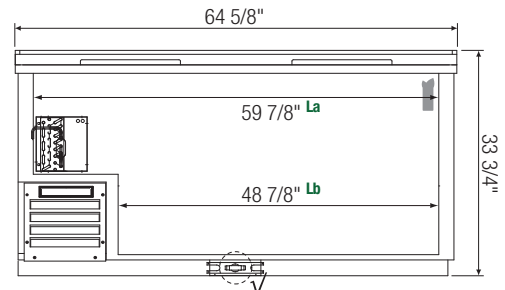
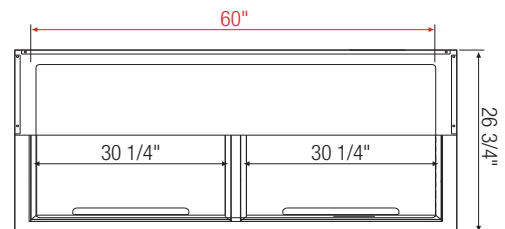

EGC65

Model	Ref/ Frz/ Dual	# of Lids	Capacity (Cu. Ft.)	Capacity (8" Mugs)	# of Shelves	HP	BTU/HR [†]	Refrigerant	Power (V-Hz-Ph)	Amps	Crated Weight (LBS)	Exterior Dimensions (Inches)		
												L	D	H
EGC37	Frz	1	11	160	3	1/2	1,979	R290	115-60-1	5	209	36 3/4	26 3/4	33 3/4
EGC50	Frz	2	15	230	5	1/2	1,979	R290	115-60-1	5	263	49 1/2	26 3/4	33 3/4
EGC65	Frz	2	21	290	7	1/2	1,979	R290	115-60-1	5	314	64 5/8	26 3/4	33 3/4

[†] Based on evaporating temperature of 23°F (-5°C) & condensing temperature of 131°F (55°C).

Frz = Freezer

La, Lb Interior Length

Specifications subject to change without notice.

Product dimensions are for general purposes and not absolute value. Product capacity (†) is calculated based on standard industry figures. Slight variations may exist. If dimensions and capacity are critical, please contact Everest Refrigeration.