

Dry Ager and Thawing Refrigerators – ED Series

Bottom Mounted Condensing Unit



EDA1



EDA2

Cabinet Construction

- Heavy duty stainless steel exterior with rounded corners for a hazard-free workspace.
- Insulated interior wall between compartments (applies to model EDA2).
- PFOA free, ceramic coated aluminum interior walls diffuse infrared rays which enhance the meat maturation process.
- High quality stainless steel floor.
- Galvanized steel top, bottom and rear.
- 2.5" thick high density polyurethane insulation.
- Four 5" swivel casters with locks on front set. Leg stabilizers included.

Refrigeration System

- Bottom mounted, self-contained and fully detachable Blizzard R290 condensing unit uses environmentally friendly, EPA-compliant R290 refrigerant with zero (0) Ozone Depletion Potential (ODP) and three (3) Global Warming Potential (GWP). Blizzard R290 is easily replaceable and requires no on-site brazing.
- Dual air paths with multiple electronically commutated (ECM) fan motors optimize circulation and accelerate the meat maturation process. Two fan motors for model EDA1. Four fan motors for model EDA2.
- Full-length air duct and airflow guard ensure optimal cold air circulation.
- Air circulation guard keeps floor vents from obstruction.
- Time-initiated and temperature-terminated auto defrost cycle for seamless operation.
- Large capacity, corrosion-resistant condenser and evaporator coils.
- Self-maintaining, energy-efficient condensate drain pan requires no external drains or electric heaters.
- High performance, auto-reverse condenser fan motor supports compressor ventilation and condenser coil cleaning.
- Pressure relief devices allow rapid cabinet re-entry.
- Pre-wired and ready to plug, 115V/60Hz/1Ph, NEMA 5-15P.

Lighting

- Shielded LED bar lighting with on/off switch provides bright, high color illumination at lower heat output.

Doors

- Low emissivity double glass panes.
- Self-closing with adjustable torsion system for a positive seal.
- Snap-in magnetic gasket for ease of cleaning.
- High strength, die-cast handles.
- Pre-installed locks keep your items safe from theft.
- Field reversible.

Shelving

- Four stainless steel shelves per section.
- Height adjustable stainless steel clips.

Temperature Control

- Multi-function digital controller with easy to read LED display.
- Factory preset temperature, 35°F. Temp-set range from 33°F to 54°F.
- Audible overheat protection alarm for compressor and condenser coil.

Options

- Stainless steel hangers and hooks.
- Additional shelving.
- 3" swivel casters with locks.
- 18" x 26" sheet pans
- 3.5" – 6" height-adjustable and interchangeable legs.

↔ = Interior Dimensions ←→ = Exterior Dimensions

ABS Legs



Two additional front adjustable stainless steel clad ABS legs provide extra stability when opening and closing door.

Vacuum Relief



The vacuum relief valve equalizes cabinet pressure for rapid door re-entry.



Equipped with 9 ft long NEMA 5-15P plug.

1 Hanger & Hooks (Optional)

High quality, food-grade stainless steel ideal for hanging meat on the bone.

2 Air Deflectors

Stainless steel panels aid in air circulation and enhance the dry-aging process.

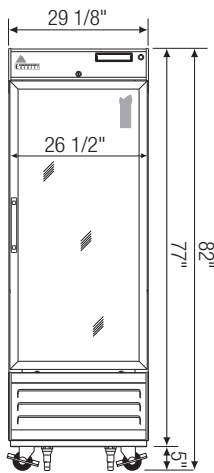
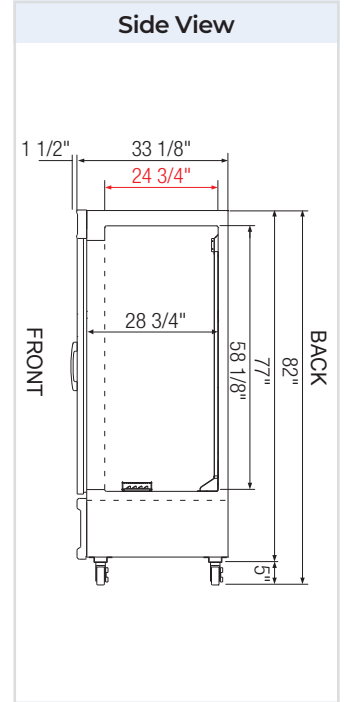
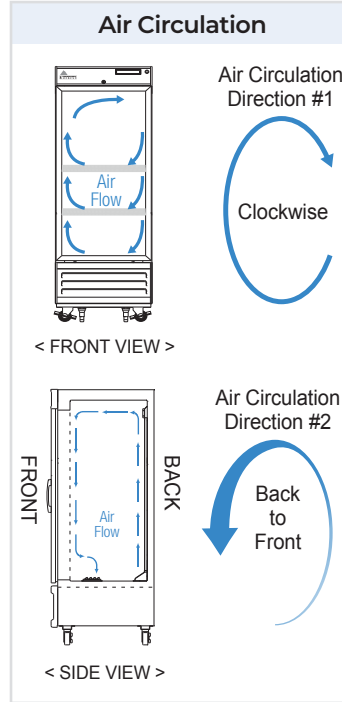
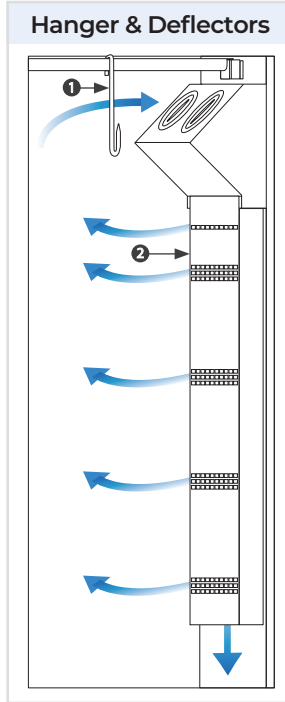

EDA1

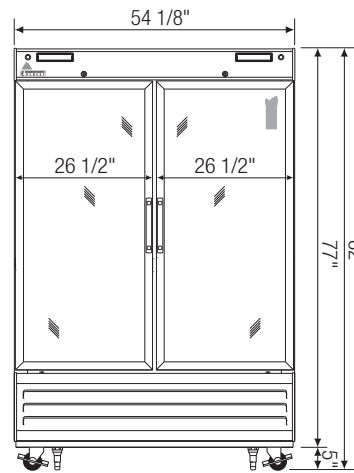
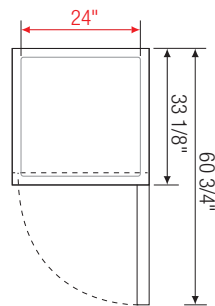

EDA2

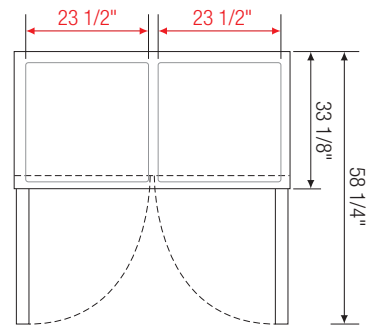

Model	Ref/ Frz/ Dual	# of Doors	Capacity (Cu. Ft.) [†]	HP	BTU/HR [†]	Refrigerant	# of Shelves	Power (V-Hz-Ph)	Amps	Crated Weight (LBS)	Exterior Dimensions (Inches)		
											L	D ^a	H [*]
EDA1	Ref	1	22	1/3	2,311	R290	4	115-60-1	2.5	390	29 1/4	33 1/8	77
EDA2	Ref	2	48	1/3 x 2	2,311 x 2	R290	8	115-60-1	5	609	54 1/8	33 1/8	77

* Height does not include 5" for casters.

† Based on evaporating temperature of 23°F (-5°C) & condensing temperature of 131°F (55°C).

^a Exterior depth dimension does not include 1-1/2" for door handles.

Ref = Refrigerator

Specifications subject to change without notice.

Product dimensions are for general purposes and not absolute value. Product capacity (†) is calculated based on standard industry figures. Slight variations may exist. If dimensions and capacity are critical, please contact Everest Refrigeration.