

DIRECT DRAW KEG REFRIGERATOR (STAINLESS STEEL)

Project Name: _____

Project Location: _____

Model #: _____ Quantity: _____

Available Warehouse: _____

EBD Series Model: EBD4-SS



Refrigeration System

- Side mounted, self-contained and fully detachable Blizzard R290 condensing unit uses environmentally friendly, EPA-compliant R290 refrigerant with zero (0) Ozone Depletion Potential (ODP) and three (3) Global Warming Potential (GWP). Blizzard R290 is easily replaceable and requires no on-site brazing.
- Electronically commutated (ECM) fan motors achieve rapid cooling with less energy consumption.
- Full-length air duct system ensures optimal circulation of cold air.
- Time-initiated and temperature-terminated auto defrost cycle for seamless operation.
- Large capacity, corrosion-resistant condenser and evaporator coils.
- Self-maintaining, energy-efficient condensate drain pan requires no external drains or electric heaters.
- High performance, auto-reverse condenser fan motor supports compressor ventilation and condenser coil cleaning. Refer to owner's manual for full maintenance instructions.
- Pre-wired and ready to plug, 115V/60Hz/1Ph, NEMA 5-15P.

Cabinet Construction

- Heavy duty stainless steel countertop and rails with textured laminate, black vinyl exterior.
- Open spaced interior with no walls between compartments.
- Galvanized steel interior walls and high quality stainless steel floor.
- Exterior T-shaped drain port routes excess moisture from the top tray. Drain hose not included. Floor drain required.
- 1 3/4" thick high density polyurethane insulation.
- Built-in caster thread receptacles for all models.

Lighting

- Energy efficient silicone coated and shatter-proof LED lighting provides bright, high color illumination with low heat output.

Doors

- Stainless steel exterior and galvanized interior.
- 1 3/4" thick high density polyurethane insulation.
- Snap-in magnetic door gasket make cleaning and replacement an easy process.
- High strength, recessed door handles.
- Pre-installed door locks keep your items safe from theft.

Draft Arms

- Two dual faucet, 3" diameter, stainless steel draft arms with matching air distributors. Fully insulated and NSF certified.

Temperature Control

- Multi-function digital controller with easy to read LED display.
- Factory preset temperature, 35°F. Temperature setting range from 33°F to 54°F.
- Audible overheat protection alarm for compressor and condenser coil.

Options

- Dual or triple faucet draft arms and matching air distributors.
- 3" or 5" swivel casters with locks.
- 3.5" – 6" height-adjustable and interchangeable legs.



Please visit our website for updated Energy Efficiency information

Ref/ Frz/Dual	Doors	Capacity		Refrigerant	HP	Power V-Hz-Ph	Amps	Crated Weight	Exterior Dimensions		
		Cu. Ft.	Barrels						L	D	H*
REF	3	32	(4) 1/2	R-290	1/3	115-60-1	2.5	455 lbs (206kg)	89.25" (2267mm)	27" (686mm)	37.25" (946mm)

(†)Based on evaporating temperature of 23°F (-5°C) & condensing temperature of 131°F (55°C). (►) Product capacity is calculated based on standard industry figures. (✳) Reference plan view for clarification on caster/unit height. If dimensions and capacity are critical, please contact Everest Refrigeration. Blizzard R290 replacement is at the sole discretion of Everest Refrigeration. Specifications subject to change without notice.

DIRECT DRAW KEG REFRIGERATOR (STAINLESS STEEL)

EBD Series Model: EBD4-SS

DIMENSIONAL DATA

External Dimensions	L	89.25" (2267mm)
	D	27" (686mm)
	H*	37.25" (946mm)
Crated Weight		455 lbs. (206kg)
Doors/Drawers/Lids		3
Max Weight Support (LBS)		-

STORAGE DATA

Net Capacity Cu. Ft. ▶	32
Shelves	-
Barrels	(4) 1/2
20 oz. Bottles	-
12 oz. Bottles	-
12 oz. Cans	-
8" Mugs	-
# of Pans (Top)	-
# of Pans (Drawer)	-
Dividers	-
Trays	-

ELECTRICAL DATA

Voltage	115-60-1
Full Load Amperage	2.5A
Feed Wires with Ground	3
Cord Length	9ft
NEMA Plug Type	 NEMA 5-15P

REFRIGERATION DATA

Compressor Mounting	Side
Refrigerant	R-290
Compressor HP	1/3
BTU/HR †	1907

KEY

D	Door	R	Refrigerator
L	Lid	REF	Refrigerator
H	Half Door	F	Freezer
FD	Full Door	FRZ	Freezer
SD	Solid Door	DUAL	REF/FRZ Combo
GD	Glass Door	DR	Drawer

	Elevation	Right	Plan	3D	Back

PLAN VIEW

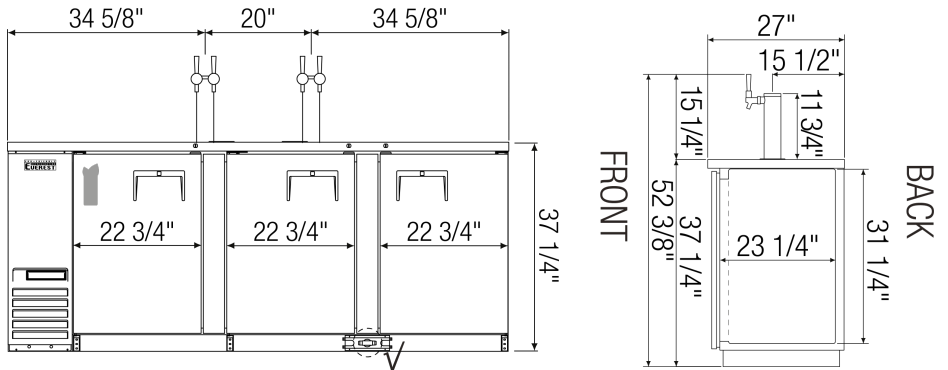

FRONT

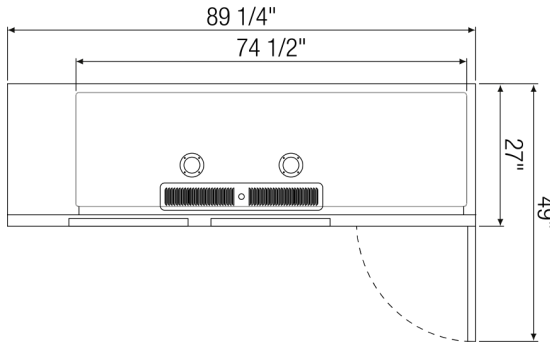

TOP

SIDE

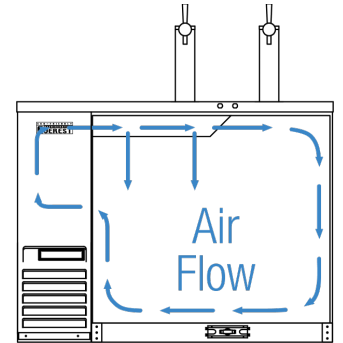

AIRFLOW

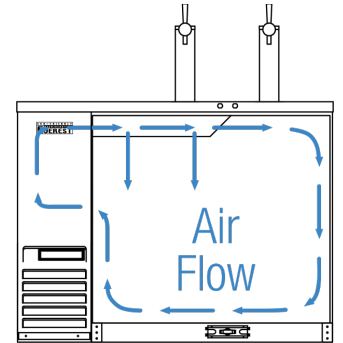

ACCESSORIES & OPTIONS

Part Number	Description
AJL03-00	Interchangeable Leg for Caster (Optional)
CASA3-02	3" Overall Height Caster Assembly - (3) Front (3) Rear
CASA5-02	5" Overall Height Caster Assembly - (3) Front (3) Rear
OAD01-00	2 Way Air Distributor
OAD02-00	3 Way Air Distributor
ODA01-00	Single Faucet 304 Stainless Steel Draft Arm, NSF Certified
ODA02-00	Dual Faucet 304 Stainless Steel Draft Arm, NSF Certified
ODA03-00	Triple Faucet 304 Stainless Steel Draft Arm, NSF Certified

(†)Based on evaporating temperature of 23°F (-5°C) & condensing temperature of 131°F (55°C). (▶) Product capacity is calculated based on standard industry figures. (✖) Reference plan view for clarification on caster/unit height. If dimensions and capacity are critical, please contact Everest Refrigeration. Blizzard R290 replacement is at the sole discretion of Everest Refrigeration. Specifications subject to change without notice.