

Chef bases (Two Drawer) – ECB Series

Side Mounted Condensing Unit



ECB36D2



ECB48D2



ECB52D2



ECB52-60D2

Cabinet Construction

- Heavy duty stainless steel interior / exterior with rounded corners for a hazard-free workspace.
- Open spaced interior with no walls between compartments.
- Galvanized steel bottom and rear.
- 2.5" thick high density polyurethane insulation.
- 16-gauge stainless steel worktop has extra layer of high-grade insulation material and integrated air chamber/vents to redirect and mitigate heat. Prevents heat-induced warping of the worktop while keeping the cabinet cold and energy cost low.
- Thick gauge stainless steel corner guards keep mounted cooking equipment from sliding off the worktop.
- Heavy duty stainless steel grips offer secure maneuverability.
- 12-gauge metal caster brackets support additional weight of mounted cooking equipment.
- Four 5" swivel casters with locks on front set. Two or three front leg stabilizers depending on model.

Refrigeration System

- Side mounted, self-contained and fully detachable Blizzard R290 condensing unit uses environmentally friendly, EPA-compliant R290 refrigerant with zero (0) Ozone Depletion Potential (ODP) and three (3) Global Warming Potential (GWP). Blizzard R290 is easily replaceable and requires no on-site brazing.
- Electronically commutated (ECM) fan motors achieve rapid cooling with less energy consumption.
- Full-length air duct ensures optimal cold air circulation.
- Time-initiated and temperature-terminated auto defrost cycle for seamless operation.
- Large capacity, corrosion-resistant condenser and evaporator coils.
- Self-maintaining, energy-efficient condensate drain pan requires no external drains or electric heaters.
- High performance, auto-reverse condenser fan motor supports compressor ventilation and condenser coil cleaning.
- Pressure relief devices allow rapid cabinet re-entry.
- Pre-wired and ready to plug, 115V/60Hz/1Ph, NEMA 5-15P.

Drawers

- Heavy duty stainless steel interior / exterior.
- 2.5" thick high density polyurethane insulation.
- Thick gauge, stainless steel frames with low-friction ball bearings.
- Snap-in, heat resistant, magnetic gaskets.
- High strength, recessed handles.
- NSF certified polycarbonate 4" deep pans (refer to the website for pan configurations).

Temperature Control

- Multi-function digital controller with easy to read LED display.
- Factory preset temperature, 35°F. Temp-set range from 33°F to 54°F.
- Audible overheat protection alarm for compressor and condenser coil.

Recommended Operating Conditions

- A minimum clearance of 6" is required between the cooking equipment's heating element and the chefbase worktop.

Options

- 3" swivel casters with locks.
- 3.5" – 6" height-adjustable and interchangeable legs.

↔ = Interior Dimensions ↔ = Exterior Dimensions

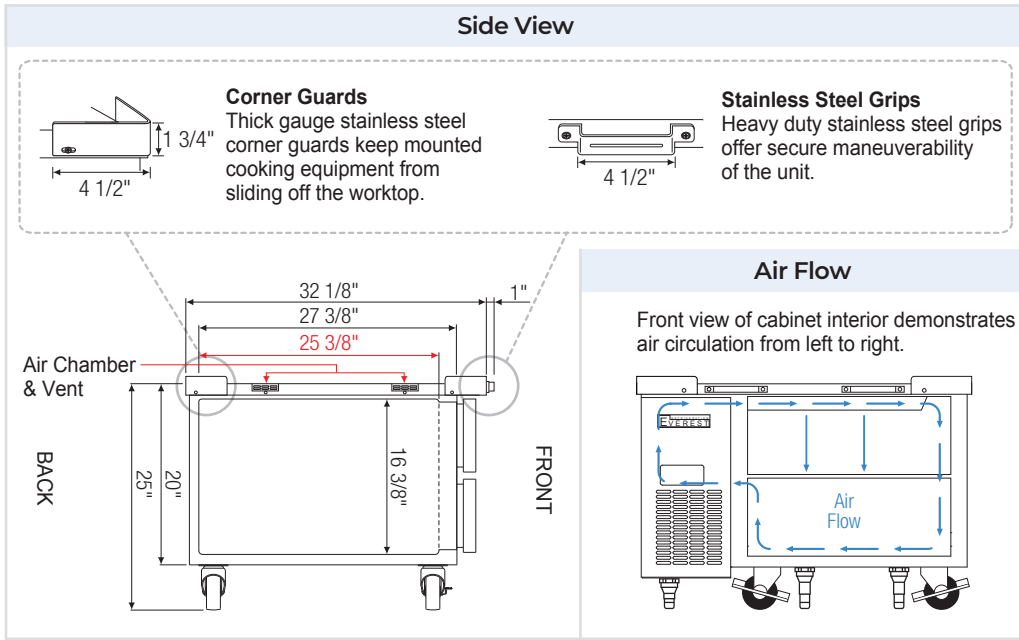

ABS Legs

Two additional front adjustable stainless steel clad ABS legs provide extra stability when opening and closing doors.

Equipped with 9 ft long NEMA 5-15P plug.

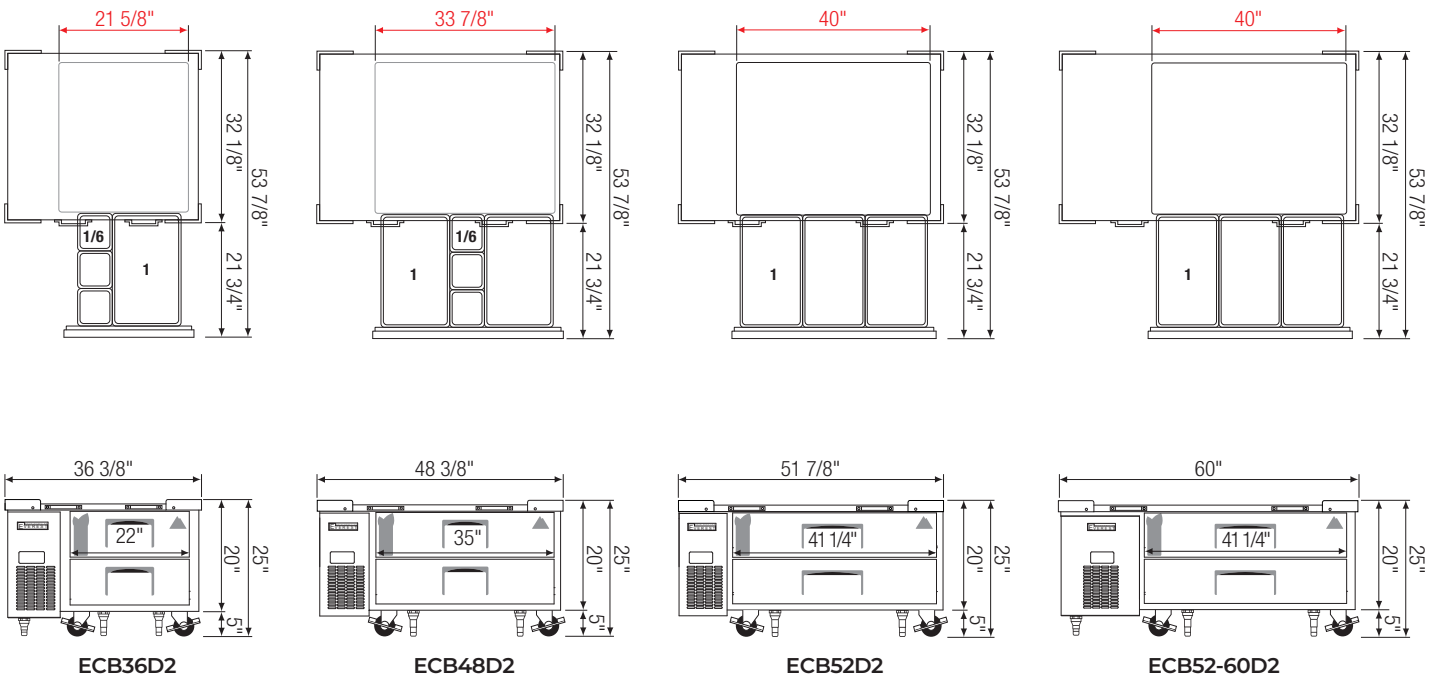

Model	Ref/ Frz/ Dual	# of Drawers	Max. Weight Support Capacity (LBS)	HP	BTU/HR [†]	Refrigerant	# of Pans	Power (V-Hz-Ph)	Amps	Crated Weight (LBS)	Exterior Dimensions (Inches)		
											L	D ^a	H [*]
ECB36D2	Ref	2	717	1/4+	1,926	R290	1 x 2 1/6 x 6	115-60-1	3.5	252	36 3/8	32 1/8	20
ECB48D2	Ref	2	717	1/4+	1,926	R290	1 x 4 1/6 x 6	115-60-1	3.5	300	48 3/8	32 1/8	20
ECB52D2	Ref	2	717	1/4+	1,926	R290	1x6	115-60-1	3.5	320	51 7/8	32 1/8	20
ECB52-60D2	Ref	2	717	1/4+	1,926	R290	1x6	115-60-1	3.5	342	60	32 1/8	20

* Height does not include 5" for casters.

† Based on evaporating temperature of 23°F (-5°C) & condensing temperature of 131°F (55°C).

a Depth does not include 1" for stainless steel grip.

Ref = Refrigerator

Specifications subject to change without notice.

Product dimensions are for general purposes and not absolute value. Product capacity (†) is calculated based on standard industry figures. Slight variations may exist. If dimensions and capacity are critical, please contact Everest Refrigeration.